

Ионекс

Тольятти: (8482) 25-82-40, (8482) 25-82-85, (927) 775-49-65, (906) 128-12-68, tlt@ionexedm.ru

Москва: (499) 782-61-17, (916) 627-56-24, (926) 300-12-42, msh@ionexedm.ru

Томск: (3822) 23-16-80, (909) 543-16-80, tomsk@ionexedm.ru

www.ionexedm.ru

CLAMPING SYSTEM MACRO

Pneumatic holders are made in version with or without air-cleaning of Z axis reference areas.

Letter „C“ in the name of the holder means automatic cleaning.

It is necessary to use hand-operated valve PM5C to control.



WPU100D-MACRO

Pneumatic holder MACRO

Fitting on a machine table with screws M10, pitch 125mm

Standard control: air-gun

Dimensions: 150x110x57mm

Clamping power: 9000N

Material INOX, hardened 54 °HRC

Available in version C

(WPU100DC-MACRO)

Accessories: hand-operated valve PM5 or PM5C



PM5



PM5C

Manual valve PM5 / PM5C for pneumatic holders



WPU56D-MACRO

Pneumatic holder MACRO
Fitting on a machine table with screws M10, pitch 80mm
Standard control: air-gun
Dimensions: 110x80x66mm
Clamping power: 4000N
Material INOX, hardened 54 °HRC

Available in version C
(WPU56DC-MACRO)

Accessories: hand-operated valve PM5 or PM5C

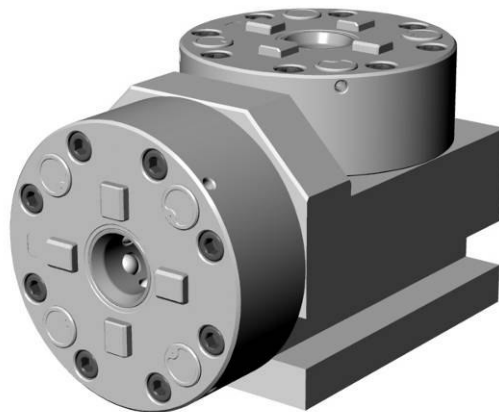

WPU100-90 MACRO

Vertical-horizontal pneumatic holder MACRO
Distance of horizontal axis from the base is 60mm
Error of clamps' perpendicularity axis up to 0,005/100mm
Standard control: air-gun
Fitting on a machine table: clamps
Dimensions: 61x100x115mm
Clamping power: 2x9000N
Material INOX, hardened 54 °HRC

Available in version C
(WPU100-90C MACRO)

Accessories: hand-operated valve PM5 or PM5C

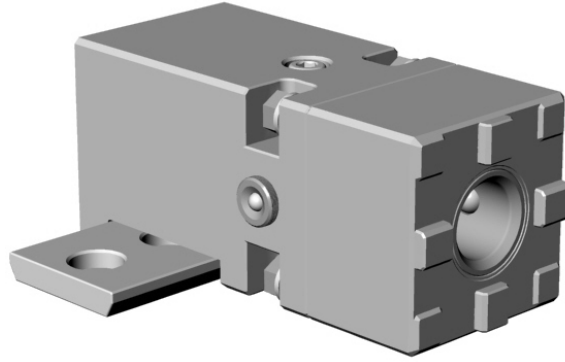

WPU56H-MACRO SET

Horizontal pneumatic holder MACRO for WEDM
Direct fitting on a machine table with screws M8, pitch 25mm
Standard control: air-gun
Dimensions: 127x56x56mm
Clamping power: 4000N
Material INOX, hardened 54 °HRC

Available in version C
(WPU56HC-MACRO)

Accessories: hand-operated valve PM5 or PM5C



WMU56V-MACRO SET

Vertical manual holder MACRO for WEDM
Direct fitting on a machine table with screws M8, pitch 25mm
Dimensions: 152x56x27mm
Material INOX, hardened 54 °HRC

MEASURING POINTERS FOR EDM



WSK-MACRO

Pointers with gentle setting to zero and changeable ball contacts
Material INOX, hardened 54 °HRC
Dimensions: 54x54x130

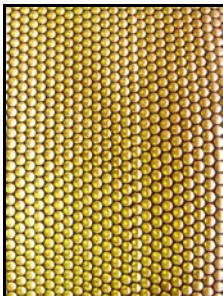

Ионекс

Тольятти: (8482) 25-82-40, (8482) 25-82-85, (927) 775-49-65, (906) 128-12-68, tlt@ionexedm.ru
Москва: (499) 782-61-17, (916) 627-56-24, (926) 300-12-42, msk@ionexedm.ru
Томск: (3822) 23-16-80, (909) 543-16-80, tomsk@ionexedm.ru

www.ionexedm.ru



MS4

Measuring ball contact for WSK
Contact stem is made of hardmetal
Delivered diameters: 2,4,6 mm.
Dimension: L=130
Material INOX

ADAPTERS



WR54MACRO-ITS

Adapter from system MACRO into system ITS
Dimensions: 54x54x30
Material INOX, hardened 54 °HRC



WUJ50 MACRO

Adapter from system MACRO into system JUNIOR
Dimensions: 54x54x50
Material INOX, hardened 54 °HRC

HOLDERS WQM

for electrodes of square profile 15x15 or 25x25



WQM15-MACRO

Holder for profile 15x15mm
Axis distance of the quadrant's wall is $7,50 \pm 0,003$
Reference height Z is $40,00 \pm 0,003$
Material INOX, hardened 54°HRC



WQM25-MACRO

Holder for profile 25x25mm
Axis distance of the quadrant's wall is $12,50 \pm 0,003$
Reference height Z is $40,00 \pm 0,003$
Material INOX, hardened 54°HRC



Copper semi-products for holders WQM

Dimensions 15x15x75 or 25x25x90



Graphite semi-products for holders WQM

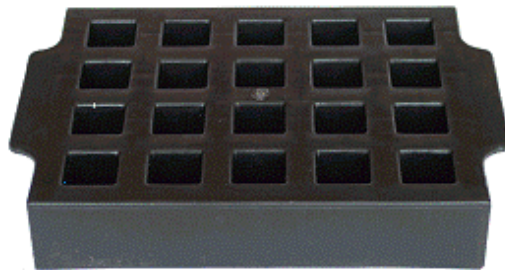

E-BOX20

Plastic box for 20pc of electrodes 15x15

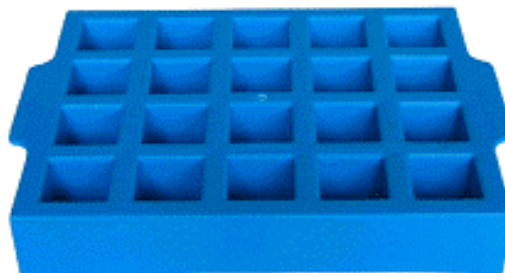

E-BOX25

Plastic box for 20pc of electrodes 25x25

COLLET CHUCKS WER

for electrodes of circular profile and tube electrodes



WER16L-MACRO

Collet chuck for collets ER16
„L“ - prolonged version
Axial alignment max. error up to 0,002
Material INOX, hardened 54 °HRC
Nut is made of case-hardening steel



WER32-MACRO

Collet chuck for collets ER32
Axial alignment max. error up to 0,002
Material INOX, hardened 54 °HRC
Nut is made of case-hardening steel

ND50 - tilting board with indexing



ND50 Q26

For easy gripping and setting of electrode angle,
for example when machining tunnel inflows.
The system is equipped with hydraulic brake so as to provide for required position.
Scale with indexing by 1° makes angle positioning easy and fast.
Electrodes are clamped into the prismatic hole 15x15mm.
The angel is possible to set on a scale 0° - 160°. Max. load: 5kg
In the picture there is a board on a pallet ITS.

NDU5 - universal tilting board

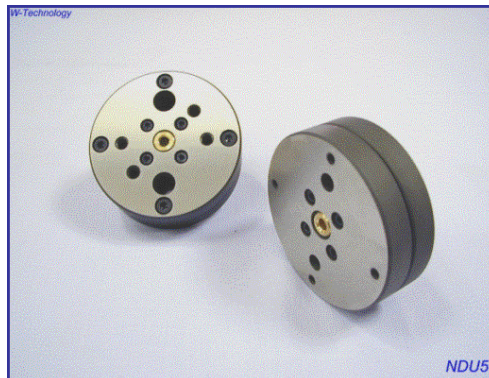

Makes electrode aligning easier – plane, perpendicularity.
Electrodes and different adapters can be fastened to the board, or
collet chuck ER32.
Board is fastened to pallets MACRO.
Pitch of fixing holes for screws M6 is 40mm
Setting range: $\pm 1^\circ$
Max. load: 5kg

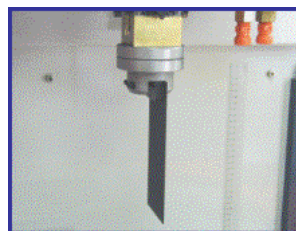
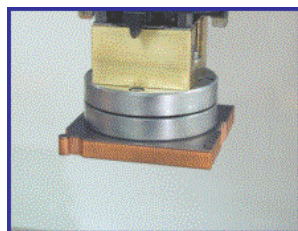

MACRO PALLETS



MACRO 50-12

Pallet MACRO
Dimensions: 54x54x12,50
Reference areas are lapped
Material INOX, hardened 54°HRC

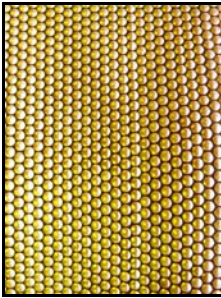

Ионекс

Тольятти: (8482) 25-82-40, (8482) 25-82-85, (927) 775-49-65, (906) 128-12-68, tlt@ionexedm.ru

Москва: (499) 782-61-17, (916) 627-56-24, (926) 300-12-42, msk@ionexedm.ru

Томск: (3822) 23-16-80, (909) 543-16-80, tomsk@ionexedm.ru

www.ionexedm.ru