



# Ионекс

Тольятти: (8482) 25-82-40, (8482) 25-82-85, (927) 775-49-65, (906) 128-12-68, [tlt@ionexedm.ru](mailto:tlt@ionexedm.ru)

Москва: (499) 782-61-17, (916) 627-56-24, (926) 300-12-42, [msh@ionexedm.ru](mailto:msh@ionexedm.ru)

Томск: (3822) 23-16-80, (909) 543-16-80, [toms@ionexedm.ru](mailto:toms@ionexedm.ru)

[www.ionexedm.ru](http://www.ionexedm.ru)

## Zeroline RoFlex

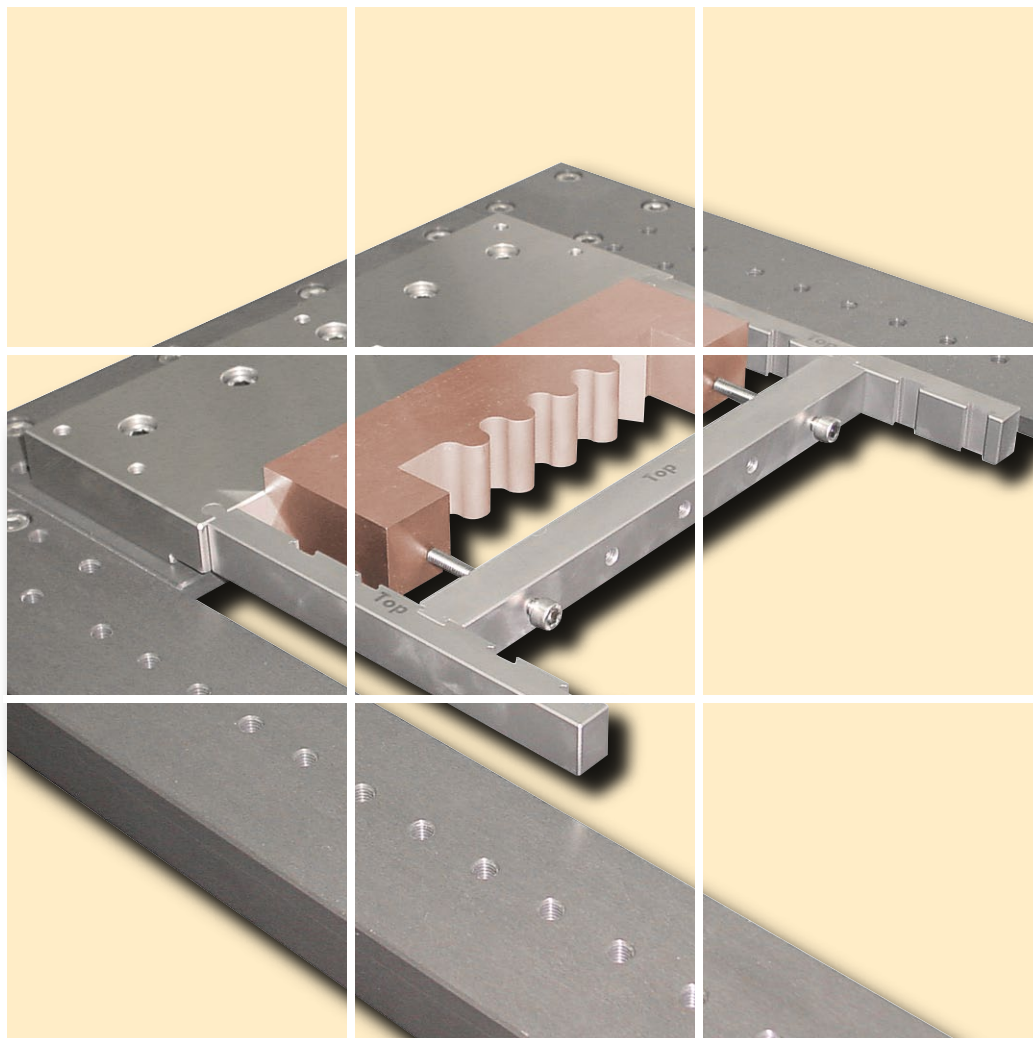

# CLAMPING FRAME ZEROLINE ROFLEX

**The New Clamping System for Wire Cut EDM.  
Suitable for all Wire Cut EDM Machines.**

## Clamping Frame Zeroline RoFlex

- Rugged, stable manual clamping of workpieces
- Clamping frame mountable without screws and reference elements
- Flexibly adjustable
- Positive connection elements
- Simple handling
- Patent pending

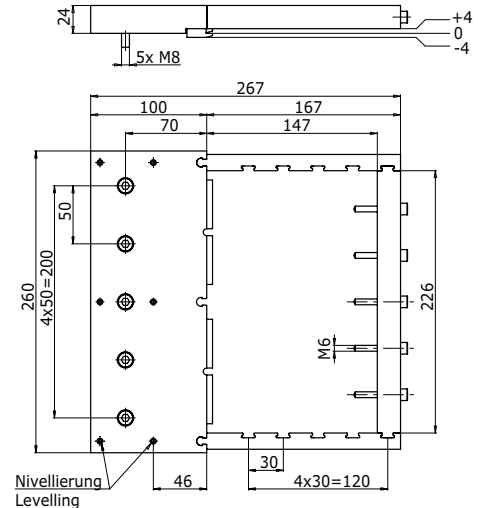
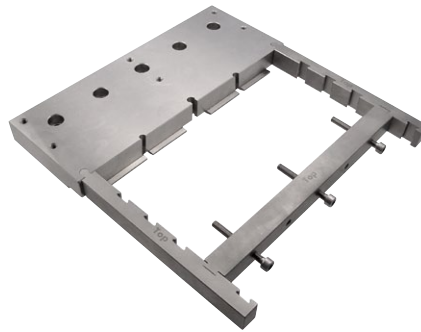

## Clamping Frame Zeroline RoFlex C 980 010

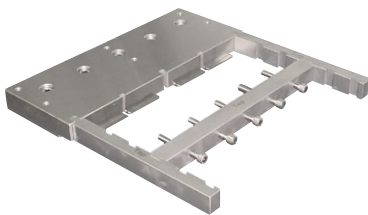

## Expansion Set Zeroline RoFlex C 980 090

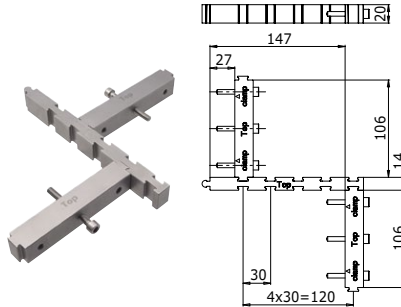

## Complete Set Zeroline RoFlex S 161 000

(C 980 010 + C 980 090)

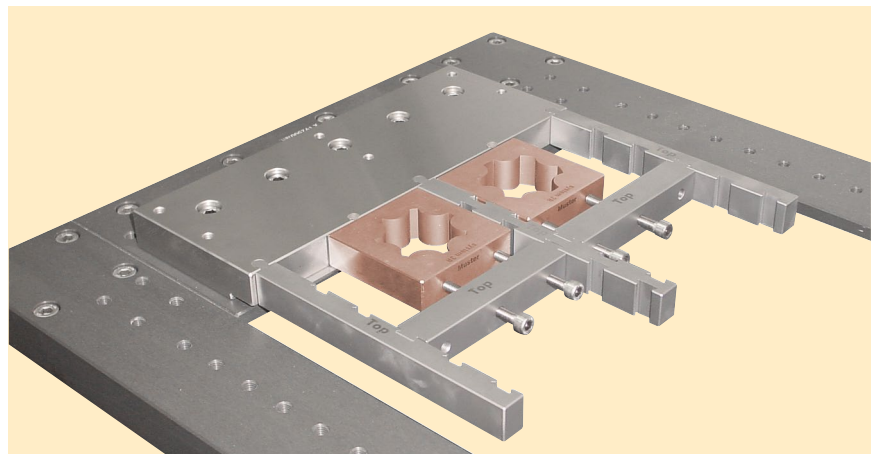
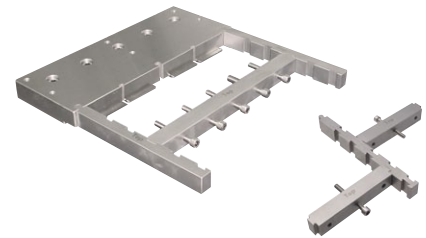

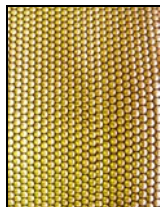

# Ионекс

Тольятти: (8482) 25-82-40, (8482) 25-82-85, (927) 775-49-65, (906) 128-12-68, [tlt@ionexedm.ru](mailto:tlt@ionexedm.ru)

Москва: (499) 782-61-17, (916) 627-56-24, (926) 300-12-42, [msk@ionexedm.ru](mailto:msk@ionexedm.ru)

Томск: (3822) 23-16-80, (909) 543-16-80, [tomsk@ionexedm.ru](mailto:tomsk@ionexedm.ru)

[www.ionexedm.ru](http://www.ionexedm.ru)

## Quick Installation on each machine table

Mounting with M8,  
hole pattern 50 mm

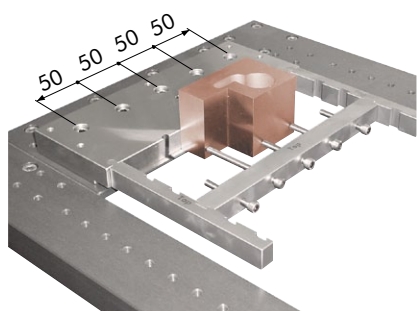

Adjusting screws for the  
alignment of workpieces

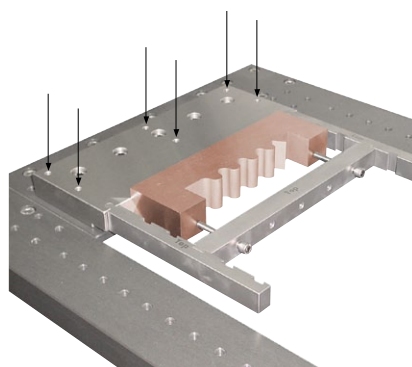

Easiest handling due to  
patented system of fits

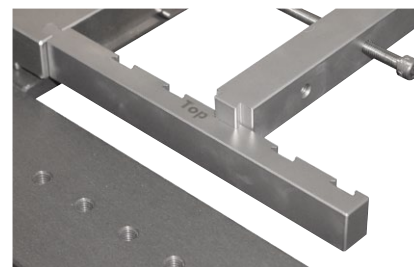

## Execution for Unimatic or Macro

